

Installation Instructions

The All-On-One-Board Pre-Amplifier covers a range from 1.8 to 30 MHz and provides a selectable gain of 0db, ~6dB and ~12dB.



Installation of the Pre-Amplifier

1. Install the pre-amplifier with the component side down on the chassis wall above the loudspeaker.
2. Unsolder coax cable from soldering terminal of the HP-filter.
3. Solder the coax cable to the soldering terminal 'from LPF' of the pre-amplifier.
4. Solder a short coax cable from the terminal 'to HPF' of the pre-amplifier to terminal of the HP-filter.
5. Connect the 13,5 Volt soldering terminal to a 13,5 Volt source on the main board.

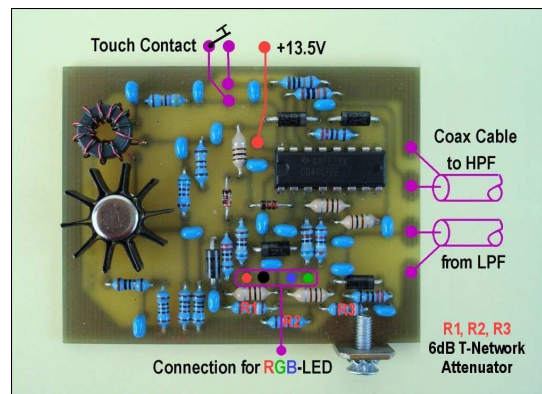

Modification of STORE push button to act as Touch-Contact-Switch.

1. Unsolder wire '8' and '9' from 'STORE' push button switch.
2. Solder an 'L' shaped limiting stop '10', made out of a 1.5mm copper wire, to the centre connection of the push button switch. Wire 'A' is leading to the touch contact terminal on the pre-amplifier board.
3. Remove notch lever '6' and keep safe for later use.
4. Solder wire 'A' to the Touch Contact terminal on the pre-amplifier board.

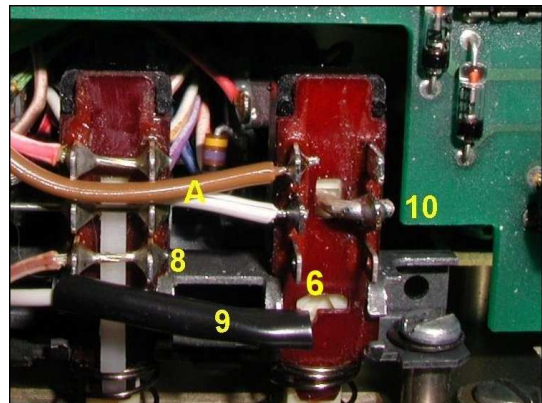

Installation of Gain Indication LED

1. Drill a hole at a suitable location on the front panel to accommodate the LED-holder. See picture above.
2. Solder 4-core cable to the LED and to the terminal on the pre-amplifier board marked as red, black, blue and green.
3. To improve light dispersion of the LED, remove 2mm from the lens part. A little disc of approx. Ø 5mm made from a 2mm Teflon sheet has been fitted and glued into the LED holder to soften the light emission.



Re-labelling upper panel

- Unplug and unscrew the UP, DOWN, STORE push button switch on the inside of the Radio.
- Unscrew one of the black PVC side panels.
- Slide acryl glass cover and upper panel to the open side.
- Pull off the protection film from the supplied self-adhesive **PRE-AMP** label.
- Use tweezers to place label centred over the **STORE** imprint and press gently onto the upper panel.
- Reassemble upper panel, acryl glass cover, UP, DOWN, PRE-AMP push button switch and side panel.

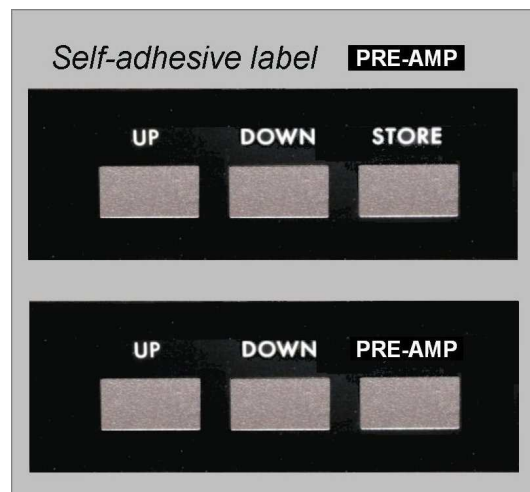

Alternative solution from PA1HF0/DK4DDS

To avoid drilling holes into the front panel, and to keep the original condition of the TR7 install a sub-panel on the bottom to accommodate the touch contact switch and multicolour LED.

Willi Rass – DF4NW
Richard-Strauß-Str. 56
91315 Höchstadt
Germany

URL: <http://www.df4nw.de>



NWT 4 Linux & Windows 15 Oktober 2008, 10:26

Startfrequenz: 1.000000 MHz; Endfrequenz: 30.001880 MHz
Schrittweite: 29.060 kHz; Messpunkte: 999

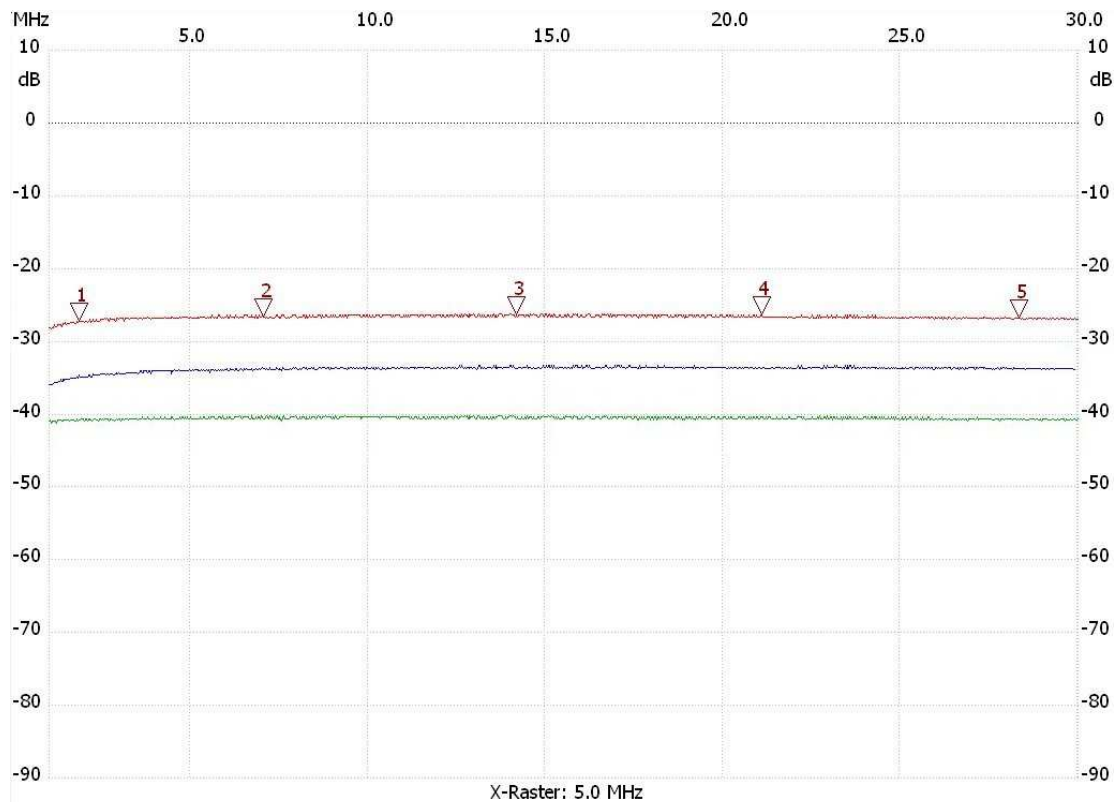

The -40dB line represents 0dB gain

Low Gain (~6dB)

Kursor 1:

1.842798 MHz

Kanal1: -34.86dB – -40dB = 5.14dB

Kursor 2:

7.044896 MHz

Kanal1: -33.91dB – -40dB = 6.08dB

Kursor 3:

14.165086 MHz

Kanal1: -33.71dB – -40dB = 6.29dB

Kursor 4:

21.081842 MHz

Kanal1: -33.52dB – -40dB = 6.48dB

Kursor 5:

28.376404 MHz

Kanal1: -33.71dB – -40dB = 6.29dB

Kanal 1

max:-33.33dB 22.476818 MHz

min:-36.20dB 1.058124 MHz

High Gain (~12dB)

Kursor 1:

1.842798 MHz

Kanal2: -27.20dB – -40dB = 12.80dB

Kursor 2:

7.044896 MHz

Kanal2: -26.63dB – -40dB = 13.37dB

Kursor 3:

14.165086 MHz

Kanal2: -26.63dB – -40dB = 13.37 dB

Kursor 4:

21.081842 MHz

Kanal2: -26.63dB – -40dB = 13.37dB

Kursor 5:

28.376404 MHz

Kanal2: -26.63dB – -40dB = 13.37dB

Kanal 2

max:-26.24dB 12.421366 MHz

min:-28.16dB 1.029062 MHz